

## Lect. 2: Review of Basic Circuits (1) (Razavi 1.3.4)

---

Consider an amplifier (linear model)

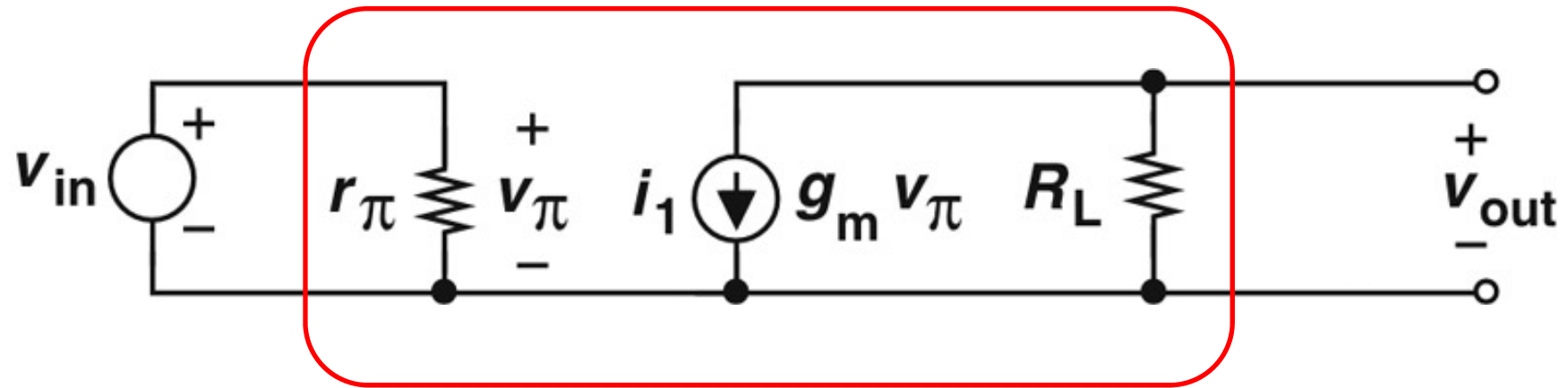

- Voltage gain:

# Lect. 2: Review of Basic Circuits (1)

---

Consider an amplifier (linear model)

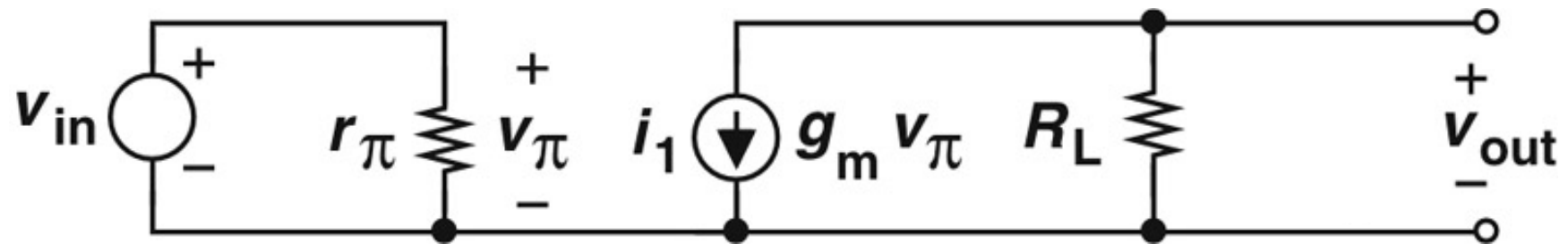

- Thevenin equivalent circuit:

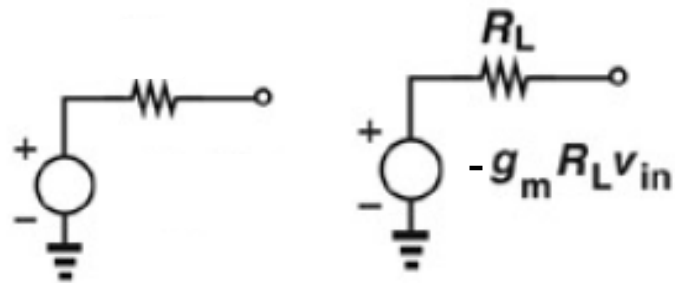

# Lect. 2: Review of Basic Circuits (1)

---

Consider an amplifier (linear model)

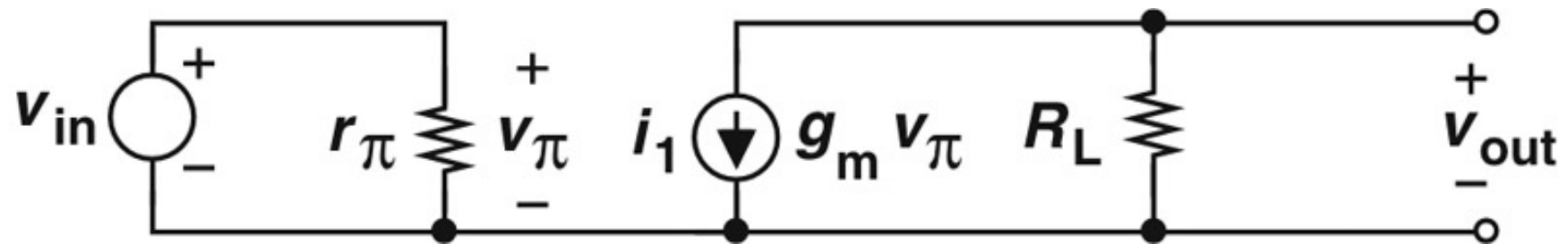

- Norton equivalent circuit:

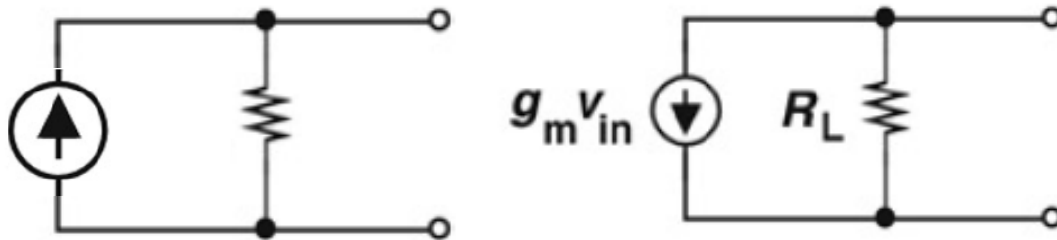

## Lect. 2: Review of Basic Circuits (1)

---

Consider another type of an amplifier (linear model)

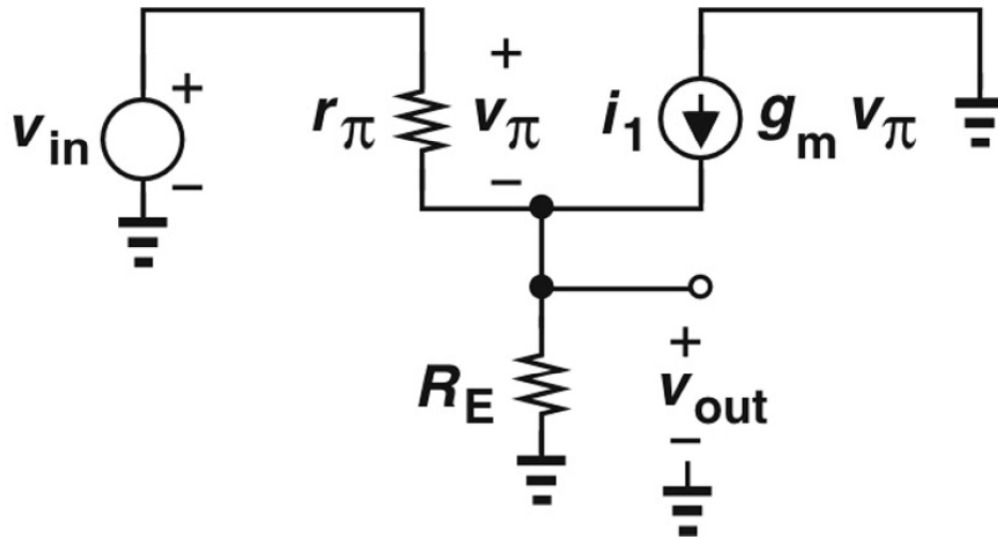

- Voltage gain:

## Lect. 2: Review of Basic Circuits (1)

---

Consider another type of an amplifier (linear model)

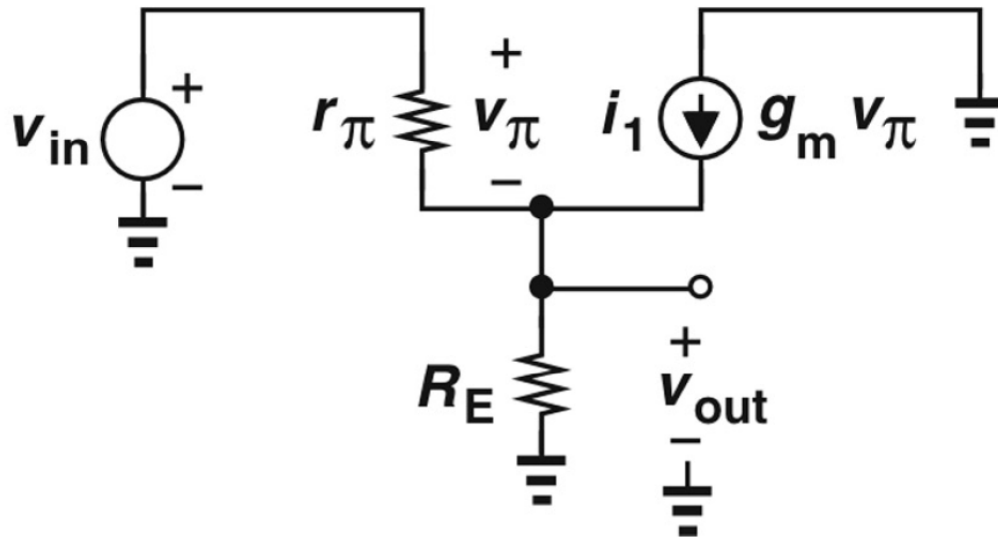

- Thevenin equivalent circuit:

# Lect. 2: Review of Basic Circuits (1)

Consider another type of an amplifier (linear model)

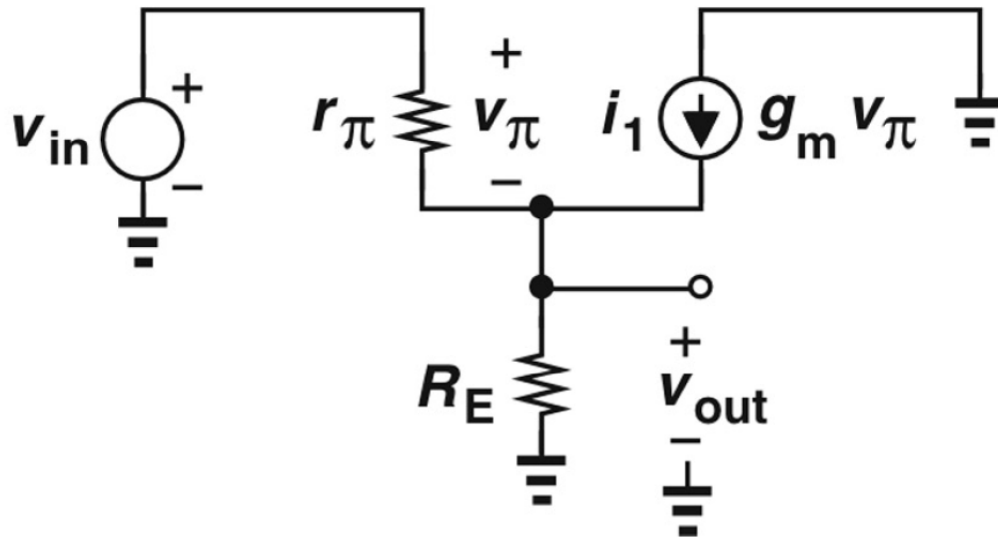

- Norton equivalent circuit:

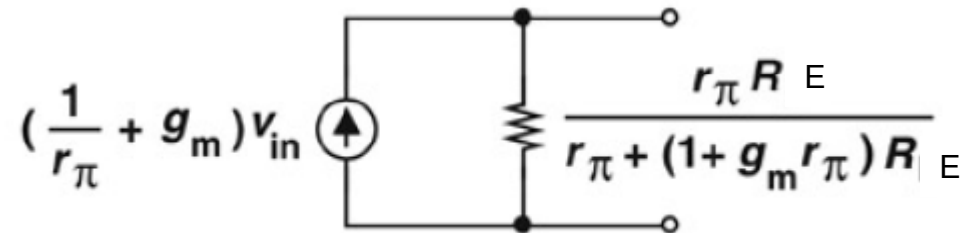

# Lect. 2: Review of Basic Circuits (1)

---

Homework: Due on 9/7 before tutorial

- Determine  $v_{out}/v_{in}$ , Thevenin, and Norton equivalent circuits for the following amplifier

